



## AGENDA

**Port of Bandon**  
 Regular Commission Meeting  
 February 23, 2022, 5:00pm  
 Bandon Public Library  
 Bandon, OR and via ZOOM  
[www.portofbandon.com/meetings](http://www.portofbandon.com/meetings)  
 for details

<b>A.</b>	<b>Consent Calendar</b>		
i.	January Minutes	Commissioners	A-B
ii.	January Financials	Commissioners	C-N
<b>B.</b>	<b>Presiding Officer and Commissioners Comments</b>		
<b>C.</b>	<b>Ordinances and Resolutions</b>		
i.	Public Hearing on Exemption	Jeff/Commissioners	Verbal
ii.	2023-03 Adopting Draft Findings/Launch Ramp	Jeff/Commissioners	1-5
<b>D.</b>	<b>Public Contracts and Purchasing</b>		
	Steel Ramp Rails Procurement	Jeff/Commissioners	6-10
<b>E.</b>	<b>Public Speaker</b>		
i.	Elakha Alliance Presentation	Bob Bailey/Commissioners	Verbal/H.O.
<b>F.</b>	<b>Port Managers Report</b>		
i.	Marina Update and Schedule		11
ii.	WRCA Request	Jeff/Commissioners	Verbal
iii.	D.C. PNWA / Commission Meeting Date	Jeff/Commissioners	Verbal
iv.	Petition to List Oregon Coast Chinook Salmon Under	Jeff/Commissioners	Verbal/H.O.
<b>G.</b>	<b>Port Staff Reports</b>		
i.	Harbormaster	Shawn/Commissioners	Verbal
ii.	Events/Leases/Moorage	Josh/Commissioners	Verbal
<b>H.</b>	<b>Public Comment</b>		
<b>I.</b>	<b>Adjournment</b>		

NOTES:

Port of Bandon  
Regular Commission Meeting & Annual Work Session  
January 26, 2023, 11:00 am  
Boardwalk Picnic Shelter  
Bandon, OR

Commissioners Present: Reg Pullen, Donny Goddard, Rick Goche, Wayne Butler, and Rod Taylor  
Staff: Jeff Griffin - Port Manager, Josh Adamson - Project Manager, Kathy Reed – Finance Director,  
Shawn Winchell - Harbormaster  
Guests: John Towne, Eileen Quinn, Annie Williams, Lori Osborne, Barry Osborne

Commissioner Pullen opened the meeting at 11:05pm

Commissioner Pullen asked for a motion to approve the consent calendar. **A motion was made by Commissioner Taylor. Commissioner Goddard seconded motion. Motion passes unanimously.**

Resolution 2023-01 was presented detailing the adoption of the Port of Bandon into the Coos County Natural Hazard Mitigation Plan. **Motion was made by Commissioner Goddard to adopt Resolution 2023-01. Seconded by Commissioner Butler. Motion passed unanimously.**

Resolution 2023-02 was presented authorizing the use of funds from the General Budget to purchase the Bandon Bait Shop building. The Port and Bandon Bait signed a lease in 2015 granting the Port of Bandon right to first refusal on the purchase of the building located at 110 First St SE at 50% real market value in 2025 or when the current lease is terminated. **Motion was made by Commissioner Goche to adopt Resolution 2023-02. Motion seconded by Commissioner Taylor. Motion passed unanimously.**

A proposed lease was discussed with Farm and Sea to lease out the entire Fisheries Building. Currently Farm and Sea operations encompass almost half the building. A new lease was drafted with a provision that a Farmers Market stay in operation. A newly modified conditional use permit allows Farm and Sea to expand under certain conditions in the C-3 zone. Commissioner Goche expressed that specific language dictating the parameters of a farmers' market wasn't included. A discussion on if or how to dictate the parameters lead to staff recommending the lease as written. Jeff stated this is a good opportunity for the Port as the Port has struggled with a permanent use for the building and has only housed a Fish Market and a seasonal 2 day a week Farmers Market. This would ensure full time use. With the new lease, the Port would see a 10-15% increase in revenue each year compared to the revenue generated by both operations annually. **Commissioner Goddard made a motion to approve the Farm and Sea lease proposal as written. Commissioner Butler seconded. Motion passed unanimously.**

**Griffin reported** the following:

A gangway off Webers Pier to the transient mooring dock (crab dock) has broken during recent storms. West Coast Contractors (WCC) were contracted to make the repairs in the amount of \$5,700. The Port is looking into federal funding for other repairs made during the recent storms.

A

WCC has been working with KPFF Engineering to finalize a 50% design of the new marina. Preliminary designs were presented correcting an error in scale with the previous 30% design and new corrected layouts from KPFF. A discussion was had by Commissioner Butler and Goche detailing the landings and fish cleaning station locations.

A grant submitted to the Oregon State Marine Board (OSMB) has been approved. Jeff attended a meeting in Salem to discuss the Port's application with the Board. \$1.99 million was approved for the launch ramp project and various components of the marina project, as well as a percentage of the dredging work. Some funds under the grant will not be available right away as they have not been adopted yet into OSMB's 2023-2024 budget. Commissioner Goche asked how long the project will take leaving the marina empty. Jeff answered about 6 months.

In a legislative update, two proposed bills are sponsored by David Brock Smith with help from Jeff detailing the need for reevaluation of permits and harvesting of sea urchins and a small mouth bass bounty. More information will be available later from Oregon Department of Fish and Wildlife.

Vicki Afatatti will need to move her mural project to another location as the paint being used will not cure in the colder environment of the Fisheries Building. Options for indoor or enclosed heating were discussed.

**Staff Report:**

Shawn reported that piles have broken in the marina during recent storms from heavier boats and waves. Staff is looking into federal, state and local funding for repairs needed in disaster relief. A vessel sunk recently due to mechanical failure of the bilge pump. Salvage efforts were successful by the Berry Brothers and Port staff and equipment. The table inside the picnic shelter has been refinished. Commissioners commented saying it looks nice. Josh distributed a handout from Dave Romanowski of the Coquille River Detachment charity who lobbied the Port for funds for fishing pole donations at Christmas time. The Port had donated \$1,000 to the charity.

**Public Comment:** John stated the goal of the Port three years ago was transparency and felt the lease for Farm and Sea did not hold to that process. Eileen Quinn stated that all communities have a Farmers Market and previous vendors did not attend this year because of changes made. She stated the market had poor advertising and expressed concern over the lease with Farm and Sea. "Bandon deserves to have a market", Eileen said.

Regular Meeting was adjourned at 12:24pm

Respectfully submitted by

Joshua Adamson and Kathy Reed

B



# PORT OF BANDON

390 FIRST ST SW ♦ BANDON, OREGON 97411 ♦ PHONE (541) 347-3206

## PORT OF BANDON RESOLUTION NO. 2023-03

### A RESOLUTION ADOPTING FINDINGS OF FACT, DECLARING AN EXEMPTION FROM COMPETITIVE BIDDING, AND APPROVING THE USE OF A DIRECT AWARD FOR THE BOAT LAUNCH REDEVELOPMENT PROJECT

**WHEREAS**, the Port of Bandon (“Port”), an Oregon port district formed and authorized pursuant to Oregon Revised Statutes (“ORS”) chapter 777, is subject to Oregon’s public contracting laws, including ORS chapter 279C relating to construction of public improvements; and

**WHEREAS**, ORS 279C.335 permits the Port’s Board of Commissioners, acting as the Local Public Contract Review Board, to exempt specific projects from the standard competitive bidding requirements of ORS 279C after specifically adopting written findings of fact justifying an exemption from traditional competitive bidding and use of an alternative contracting method; holding a public hearing on the adoption of the findings; and declaring an exemption from competitive bidding; and

**WHEREAS**, when approving the exemption per ORS 279C.335, the Local Contract Review Board “shall, where appropriate, direct the use of alternative contracting and purchasing practices that take into account market realities and modern or innovative contracting and purchasing methods, which are also consistent with the public policy of encouraging competition”; and

**WHEREAS**, the Port has determined that, due to numerous factors considered related to the Boat Launch Redevelopment Project (“the Project”) and the need to protect the public safety from failing infrastructure, a direct contract award is preferred; and

**WHEREAS**, the Port has prepared written Findings of Fact (“Findings”) to support the exemption from competitive bidding and the use of Direct Contract Award, which are attached hereto as Exhibit A and incorporated herein by this reference; and

**WHEREAS**, a public hearing on the Findings was duly noticed and held on February 23, 2023.

**NOW, THEREFORE,** the Port's Board of Commissioners, acting as the Local Contract Review Board, hereby resolves as follows:

1. The written findings attached hereto as Exhibit A are hereby adopted.
2. An exemption from traditional construction bidding processes is hereby declared.
3. Use of direct contract award is hereby authorized for completion of the Project.

**DATED** this 23<sup>rd</sup> day of February, 2023.

---

Reg Pullen, President

ATTEST:

---

Donny Goddard, Vice-President

## EXHIBIT A

### PORT OF BANDON

#### FINDINGS IN SUPPORT OF DECLARING AN EXEMPTION FROM COMPETITIVE BIDDING AND DIRECTLY AWARDING A CONTRACT FOR THE BOAT LAUNCH REDEVELOPMENT PROJECT

**Introduction.** After a thorough evaluation of the work required to complete the boat launch redevelopment project (“the Project”) for the Port of Bandon (“Port”), the Port’s management team has determined that the direct award approach is the preferred method to construct the Project.

ORS 279C permits the Port Commission, acting as the Port’s Local Contract Review Board, to, where appropriate, exempt competitive bidding and direct the use of alternative contracting and purchasing practices that consider market realities and that are consistent with the public policy of encouraging competition. On behalf of the Port, the Port’s Local Contract Review Board must adopt written findings in support of the alternative method; hold a public hearing to take comments on the findings; and approve a resolution adopting the findings and directing use of the alternative method.

As required by ORS 279C.335, notice of the public hearing was advertised in the *Daily Journal of Commerce* on Wednesday February 8, 2023, for a proposed hearing on Thursday February 23, 2023.

**Project Description.** The entire existing boat launch dock, ramp, and pile infrastructure is past its design life and has become an unstable and at times unsafe facility. This Project is to replace the launch ramp with a new facility with a design that responds to the needs of boaters, as well as to meet modern safety and environmental parameters.

Preliminary design work, completed by the Oregon Marine Board, is completed and was used by the Port to apply for permitting, which is now complete. The fabrication of boarding docks for this project were recently procured through an open, competitive, sealed bid process with time sensitive public funding. Funding for the remainder of this project was recently secured and final design work is now underway by the Marine Board. The Port’s goal is to complete the construction work for the launch ramp alongside a larger project, the Port’s Marina Replacement Project, which is now under contract. On-site in-water work is scheduled to begin during October of 2023.

## FINDINGS.

In support of the Local Contract Review Board's decision to declare an exemption to traditional competitive bidding the Project, Port staff provide the following findings:

- a) Reduced Cost and Time for the Port. The Port has already contracted with a marine construction firm to complete the adjacent marina replacement. Contracting with this firm for the remaining components of the smaller launch ramp project will result in lower mobilization and demobilization expenses as the contractor will already be mobilized for the marina project using much of the same equipment. Also, engaging a single firm to complete both projects during the same in-water work season is expected to shorten the number of seasons and time required to bring the Project to completion.
- b) Flexibility with Construction Processes. Using the direct award process will enable the Port to coordinate with the contractor to ensure that both projects are coordinated as efficiently as possible to address the Project's unique conditions and circumstances, while allowing for maximum flexibility to adjust the construction process if these conditions or circumstances change. Given the lack of availability of adjacent equipment staging sites, it is unlikely that another contractor could realistically locate a suitable site and bid on the project.
- c) Improved Project Delivery Schedule. Because both construction processes are dependent upon the ODFW and NMFS in-water work windows, a direct award will allow the lead contractor to closely coordinate activities in both basins from a single mobilization site resulting in an improved project delivery schedule.
- d) More Cost Certainty. Use of a direct award will allow a single contractor more certainty in the construction process than would a co-construction process where coordination of space and time could result in construction delays and cost overruns.
- e) Promote Competition. The Port recently selected the primary contractor for the much larger marina replacement project through an open, competitive process among qualified contractors, promoting overall competition on the projects. The Port also recently put out for competitive bids for the procurement of launch ramp docks. Competitive bids were received for this, reviewed, and an award was made with a separate dock construction company.
- f) Public Benefits. The direct award process, in this circumstance, promotes collaboration and efficiency to ensure the Project will be completed on time, on budget and at, or above, the quality described in the construction documents. Timely completion of the Project will make the launch ramp available to the public as soon as possible, while responsibly managing the expenditure of public funds.
- g) Specialized Expertise Required. The Port's project management team is well equipped to manage the complexities of the construction process, with experienced and qualified district

2 - WRITTEN FINDINGS IN SUPPORT OF AN ALTERNATIVE TO CONSTRUCTION CONTRACTING

staff and external project advisors such as staff at the Oregon Marine Board. In addition, the Port's legal counsel for the Project is familiar and experienced with Oregon law as it applies to construction of a public improvement and will be available to advise the Port on this process.

- h) Public Safety. The existing launch ramp structure has reached the end of its design life and poses an increased risk to public safety as it continues to deteriorate. In completing the Project, the selected firm will be required to prioritize public safety in the construction of the replacement infrastructure. The contractor also will prepare a construction safety plan for the Project to help to ensure it is built safely and with minimal safety risks during construction.
- i) Funding Sources. The Port expects to have funds available to complete the Project, using a combination of existing capital reserves and federal and state grant funds awarded thru the Oregon Marine Board, and other sources.

#### **RECOMMENDATION.**

Staff recommends the Board of Directors, acting in its capacity as the Local Contract Review Board approve these Findings of Fact supporting an exemption from the traditional method of awarding public construction contracts, and authorize the direct award process of contracting to complete the Project.



**PROPOSER'S BID FORM**

Proposer's Company Name: Beko's Welding Inc  
 Authorized Representative: Rick Beko  
 Representative's Signature: *[Signature]*  
 Date: 2-7-2023

**RAMP RAIL SYSTEM - FABRICATE, DELIVER, & OFFLOAD  
 BANDON BOAT LAUNCH  
 PORT OF BANDON**

**BASE BID**

Bid Item No.	Item	Quantity	Unit	Unit Cost	Total Cost
1	Ramp Rail System - Fabrication Complete	2	EA	\$10,035.00	\$20,070.00
2	Ramp Rail System - Delivery & Offloading	1	LS	\$900.00	\$900.00
TOTAL					\$20,970.00

**BID ALTERNATE #1 ( Section 01200 Waiver Required with this Bid)**

Bid Item No.	Item	Quantity	Unit	Unit Cost	Total Cost
1	Ramp Rail System - Fabrication Complete	2	EA	\$10,035.00	\$20,070.00
2	Ramp Rail System - Delivery & Offloading	1	LS	\$900.00	\$900.00
TOTAL					\$20,970.00

**Notes: Price Includes**

- 1 Includes all materials, fabrication and misc. items per plans and specifications
- 2 Includes profit and overhead per general conditions allowances
- 3 Delivery location is commonly referred to as the Moore Mill Log Yard at 145 Riverside Drive, Bandon, OR 97411.
- 4 Complete both bid schedules. **ONLY ONE BID SCHEDULE WILL BE AWARDED**

All Material Meets Buy American  
No Galvanizing  
Bare Steel  
All Hardware A325 Galvanized

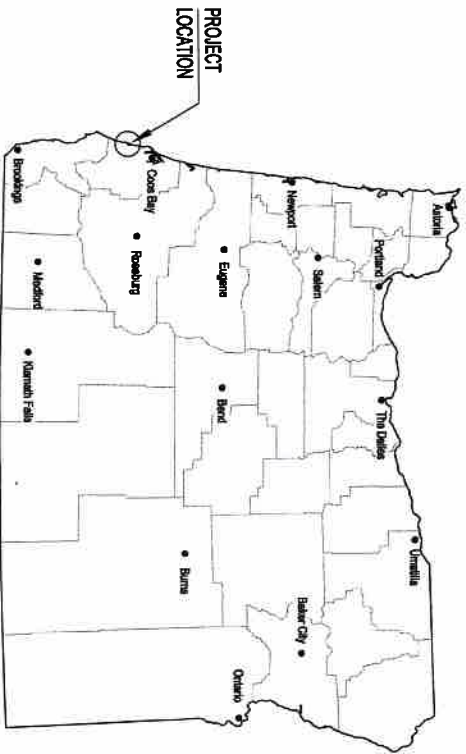

LOCATION MAP  
NO SCALE

DRAWING INDEX

- 01 - TITLE SHEET
- 02 - LAUNCH RAMP LAYOUT PLAN
- 03 - PRECAST RAIL SYSTEM DETAILS
- 04 - RAIL SYSTEM CONNECTION DETAILS

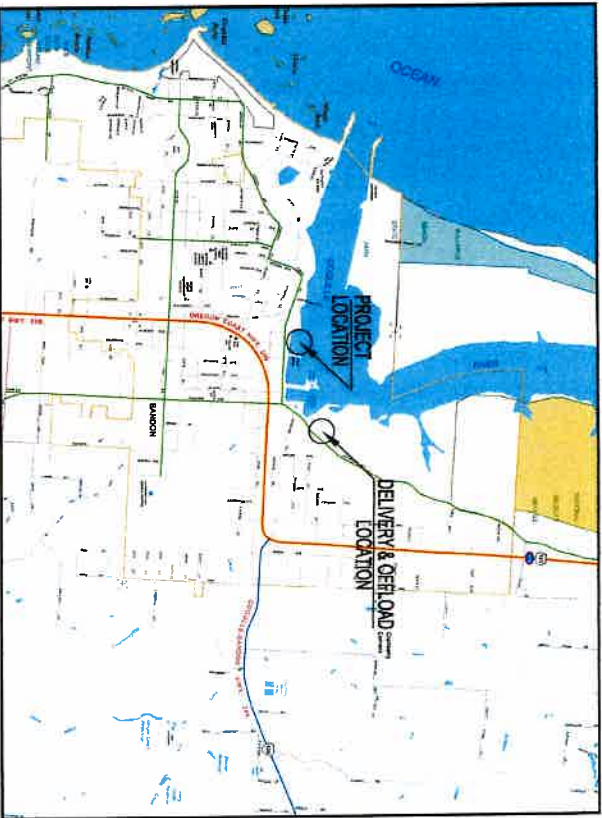

VICINITY MAP



GEOGRAPHIC LOCATION	
TOWNSHIP:	30 SOUTH
RANGE:	14 WEST
SECTION:	30
TAX LOT:	VARIES
COUNT:	COOS
LONGITUDE:	43° 23' 47" NORTH
LATITUDE:	124° 47' 42" WEST
USGS QUAD MAP:	BANDON

# RAMP RAIL REPLACEMENT AT THE BANDON BOAT LAUNCH - COQUILLE RIVER - MILE 0.8 FOR THE PORT OF BANDON



EXPIRES: 8-30-24

**FINAL**  
AS ADVERTISED



PROJECT LOCATION, WATERBODY & FACILITY OWNER:  
**BANDON BOAT LAUNCH COQUILLE RIVER MILE 0.8  
PORT OF BANDON**

SHEET DESCRIPTION:  
**TITLE SHEET**

SHEET NUMBER:  
**01**

TOTAL SHEETS:  
01 OF 04

DATE:  
04/25/18 - 1/18/19

\\qumbr022\ssd\volume\Projects\Port of Bandon\Port of Bandon\_Ramp\1718\_Materials\_Purchase\Contract Documents\Drawings\Final\Geotag\Purchase&Delivery\01\_TitleSheet.dwg

- NOTES:
- 1) RAIL SYSTEM IS FOR PROPOSED FACILITY PROJECT.
  - 2) SCOPE IS TO SUPPLY THE FABRICATED RAMP RAIL SYSTEM AND CONNECTION HARDWARE.
  - 3) CONCRETE, REBAR, AND AGGREGATE ARE NOT INCLUDED IN THIS CONTRACT.
  - 4) DELIVER AND OFF LOAD AT LOCALITY AS SPECIFIED.

CAST-IN-PLACE REBAR LAYOUT PLAN

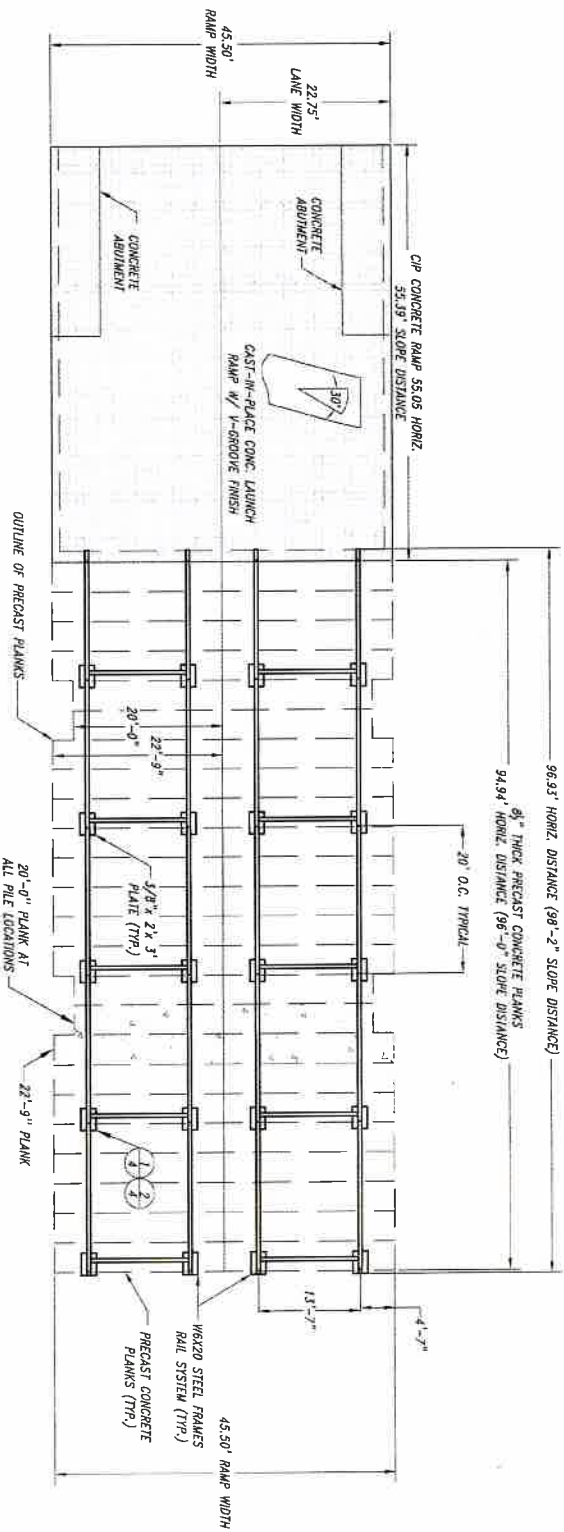

PRECAST PLANK & RAIL LAYOUT PLAN

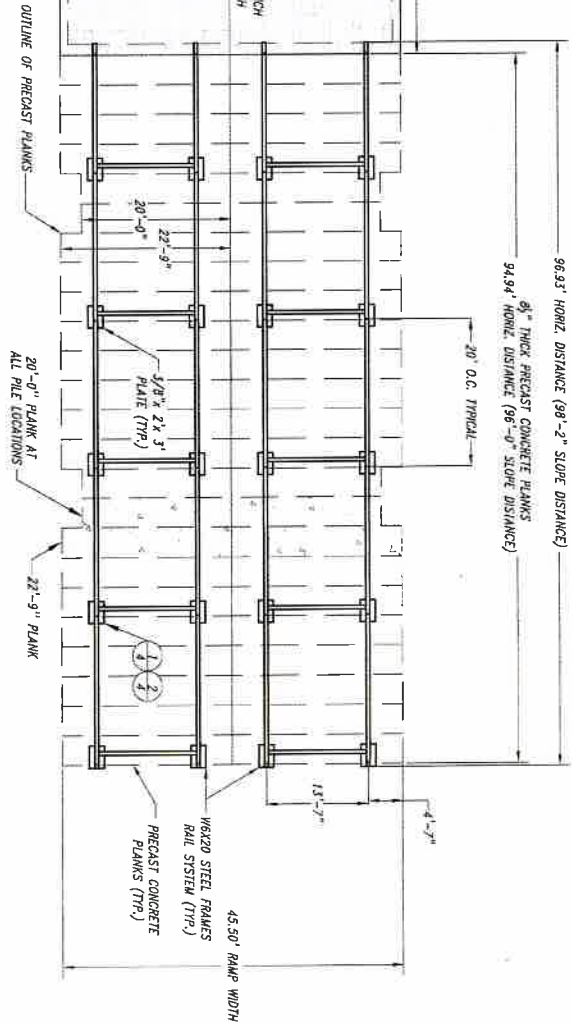

LAUNCH RAMP PLAN



02  
 SHEET 02 OF 04  
 DRAWING NO. 0005-1716-20

PROJECT LOCATION, WATERBODY & FACILITY OWNER:  
**BANDON BOAT LAUNCH, COQUILLE RIVER - MILE 0.8  
 PORT OF BANDON**

SHEET DESCRIPTION:  
**LAUNCH RAMP PLAN**

DESIGNER:  
**J. FISHER  
 M. WATTS, J. FISHER  
 DATE: 1/14/23**

STATUS:  
**FINAL  
 AS ADVERTISED**



EXPIRES: 6-30-24  
 ENGINEER

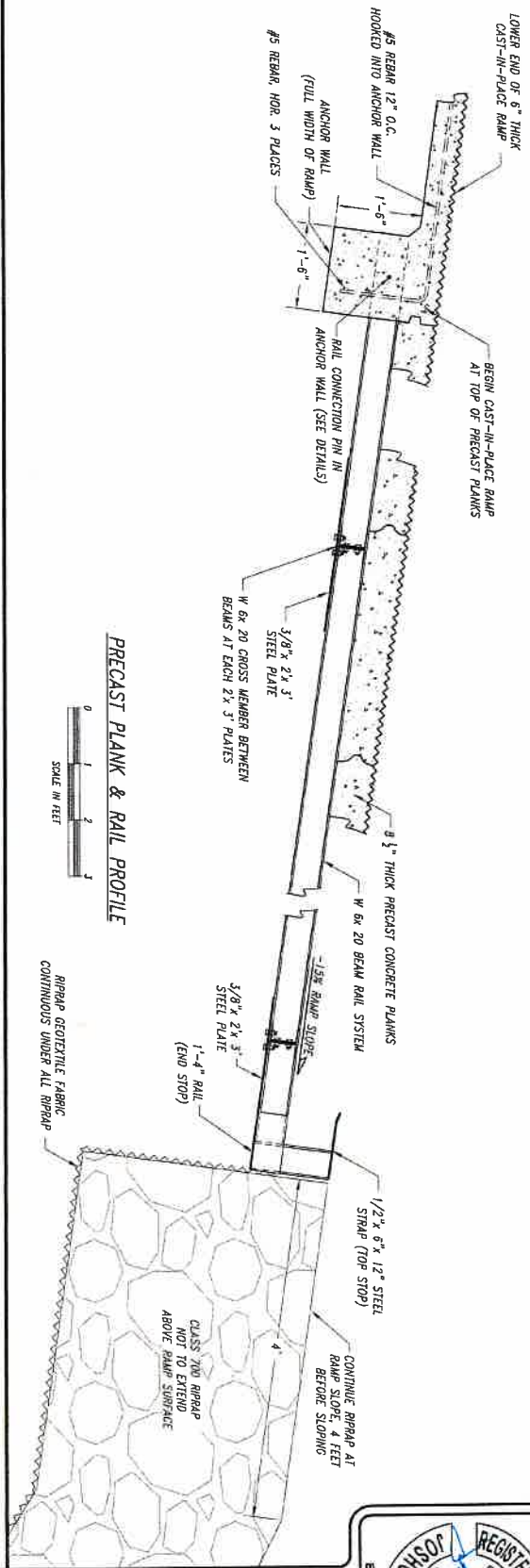

SCALE IN FEET

PRECAST PLANK & RAIL PROFILE

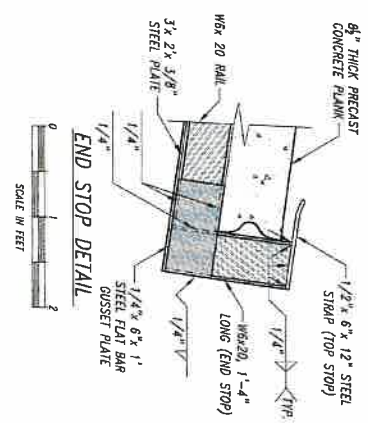

SCALE IN FEET

PLAN VIEW IN-PLACE

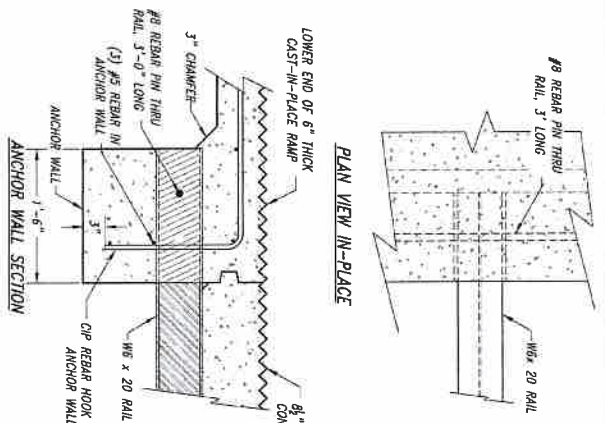

SCALE IN FEET

ANCHOR WALL CONNECTION DETAIL



SCALE IN FEET

RAIL PLAN VIEW

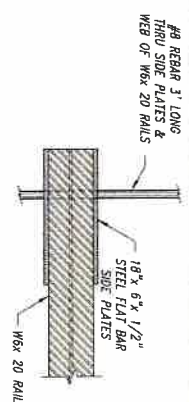

RAIL SIDE ELEVATION

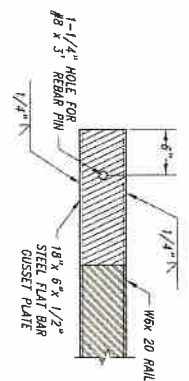

		<p>DATE: 1/29/13</p>
		<p>DESIGNED BY: J. FISHER</p>
<p>FINAL AS ADVERTISED</p>	<p>PROJECT LOCATION: WATERBODY &amp; FACILITY OWNER: BANDON BOAT LAUNCH COQUILLE RIVER MILE 0.8 PORT OF BANDON</p>	<p>03</p>
<p>SHEET DESCRIPTION: PRECAST RAIL SYSTEM DETAILS</p>	<p>PROJECT LOCATION: WATERBODY &amp; FACILITY OWNER: BANDON BOAT LAUNCH COQUILLE RIVER MILE 0.8 PORT OF BANDON</p>	<p>0005 - 1718 - 21</p>

J:\Projects\Port of Bandon\Port of Bandon Ramp\716\_Materials\_Purchase\Contract Documents\Design\Final\BDRa\Final\Deliver\03\_PrecastRailSystemDetails.dwg



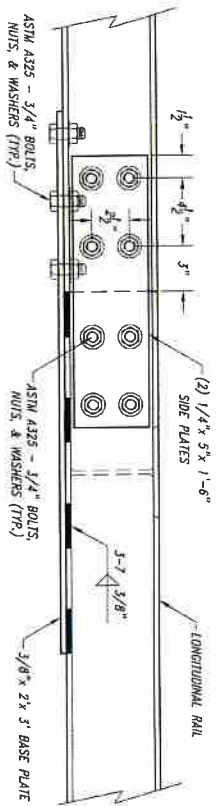

1. LONGITUDINAL RAIL SPICE ELEVATION



CONNECTION OPTION

1. 1/4" x 5" x 1"-6" SIDE PLATES - CONTINUOUS 1/4" FILET
2. LONGITUDINAL RAIL SPICE - 5/16" FILET 4-8 (BOTH SIDES)
3. COPE ENDS OF CROSS MEMBERS NOT REQUIRED, 3/16" CONTINUOUS FILET WELD CROSS MEMBER BOTTOM FLANGE TO PLATE (BOTH SIDES), 5/16" BEVEL WELD TOP AND BOTTOM FLANGE OF CROSS MEMBER TO LONGITUDINAL RAIL.

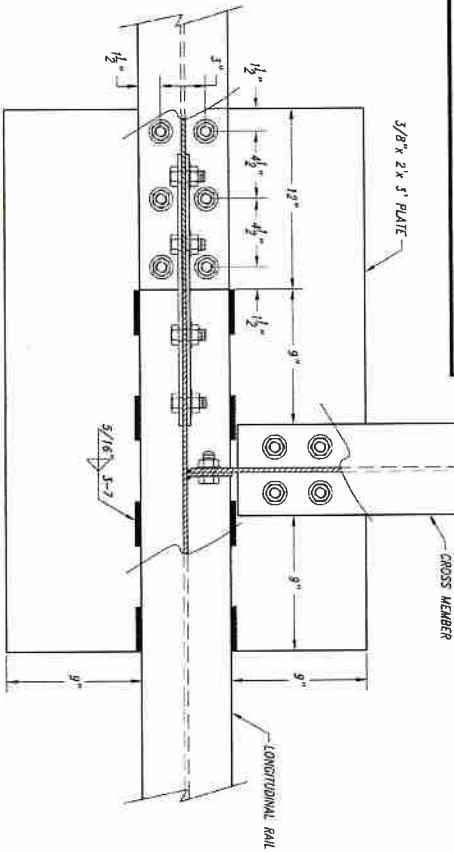

NOTE: TOP FLANGES OF WELD MEMBERS NOT SHOWN FOR CLARITY OF BOLTED CONNECTIONS.

2. LONGITUDINAL RAIL SPICE PLAN

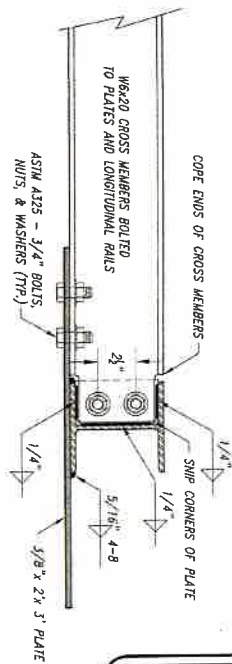

3. CROSS MEMBER CONNECTION SECTION A-A

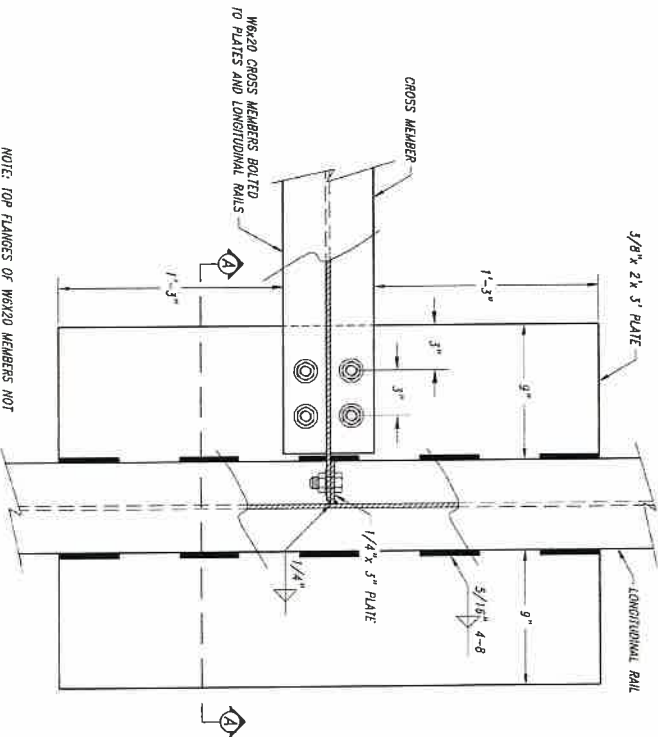
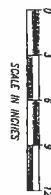

NOTE: TOP FLANGES OF WELD MEMBERS NOT SHOWN FOR CLARITY OF BOLTED CONNECTIONS.

4. CROSS MEMBER CONNECTION PLAN

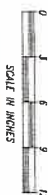

REGISTERED PROFESSIONAL ENGINEER  
 JOSHUA B. TACCHALLA  
 OREGON  
 LICENSE NO. 11,200  
 DATE 11/27/03

DESIGNED BY  
 J. FISHER  
 DRAWN BY  
 J. FISHER  
 DATE 1/24/05



PROJECT LOCATION, WATERBODY & FACILITY OWNER: BANDON BOAT LAUNCH, COQUILLE RIVER - MILE .08 PORT OF BANDON	SHEET NUMBER <b>04</b>
SHEET DESCRIPTION: RAIL SYSTEM CONNECTION DETAILS	DATE 0005-1716-02

J:\Projects\Port of Bandon\Port of Bandon Ramp\1716\_Materials\_Purchase\Connect Documents\Civil\RailPurchase&Copy\04\_SantaRailSystem-Connecto\Details.dwg

